

# PETROCHEMICAL INDUSTRY

## Rolling Bearing Solutions for LDPE and EVA High Pressure Autoclaves

The maintenance interval of high pressure autoclaves is very often defined by the service life of the motor and stirrer bearings. Although these bearings seem to be well dimensioned with regard to the relatively low weight of the motor or the stirrer they carry, the bearings normally fail after some weeks or latest some months, only. These early bearing failures are related to the poor lubrication conditions under which the bearings have to operate. Due to the high product flow through the reactor, conventional lubrication by oil and grease is not possible, because the lubricant is simply washed away by the product. The only "lubricant" which remains for the bearings, is the product itself. But the low viscosity of the media, gaseous ethylene or EVA at the motor and upper stirrer bearings and a mix of gaseous and liquefied ethylene or EVA in the lower stirrer bearing position, does not allow to build a separating film between the rolling elements and the races. As a consequence adhesive wear on the steel rolling partners leads to rapid surface degradation and subsequent bearing failure, often caused by a catastrophic cage collapse.



*CEROBEAR Hybrid Ball & Roller Bearings for High Pressure Autoclaves*

CEROBEAR's hybrid ceramic ball and roller bearings for high pressure autoclaves directly address the main source of the failure, the adhesive wear. Silicon nitride ( $\text{Si}_3\text{N}_4$ ), the material which in hybrid bearings is used for the rolling elements is formed by covalent bondings and does not comprise free electrons.

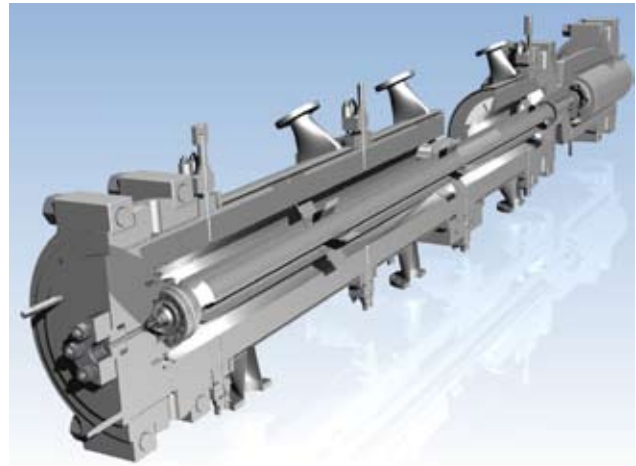

*Courtesy of UHDE*

As a consequence  $\text{Si}_3\text{N}_4$  is inert, it does not react with other materials and there is no material transition, no adhesive wear, between the rolling partners. At the same time  $\text{Si}_3\text{N}_4$  provides more than twice the hardness than bearing steel, which means that in hybrid bearings also the abrasive wear rate is significantly lower than with steel bearings. As a result the service life of hybrid bearings is between 4 to 8 times longer than the one of conventional steel bearings. Reduced reactor downtime and maintenance cost and minimized production loss over compensate the higher cost for the ceramic technology.



*Unique CEROBEAR Thrust Spherical Roller Bearing*